

Technical features _ COBRAM 60 AR

		8.25-16	250/80-18	280/70R18	320/65R18	260/70R20	31x15.50-15 XTC	31x15.50-15 STG	31x13.50-15 Garden
		WITH ADJUSTABLE RIM	WITH ADJUSTABLE RIM	WITH ADJUSTABLE RIM	WITH ADJUSTABLE RIM	WITH ADJUSTABLE RIM	WITH FIXED RIM	WITH FIXED RIM	WITH FIXED RIM
A Tyre width mm.		212	240	282	319	258	368	394	351
B Tyre height mm.		848	879	849	873	872	800	800	782
C Wheel track min/max mm.	Mono	794 - 1100	865 - 1107	869 - 1119	931 - 1119	846 - 1120	1003	1003	991
	Rev	827 - 1100	865 - 1107	931 - 1119	931 - 1119	902 - 1120			
D Width min/max mm.	Mono	1006 - 1312	1105 - 1347	1151 - 1401	1250 - 1438	1104 - 1378	1371	1397	1342
	Rev	1039 - 1312	1105 - 1347	1213 - 1401	1250 - 1438	1160 - 1378			

TRACTOR DIMENSIONS COBRAM 60 AR (mm):

	E	F	G	H	I Min-Max	L Max	M
COBRAM 60 AR	1160	1340	730	3230	220/270	2220	675

STEERING RADIUS COBRAM 60 AR WITH THE FORESEEN WHEELS:

Tyre type	8.25-16	250/80 18	280/70 R18	320/65 R18	260/70 R20	31x15.50 15	31x13.50 15
mm	2450	2500	2530	2650	2600	2700	2700

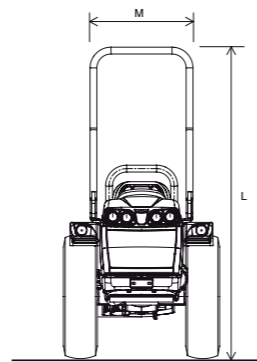
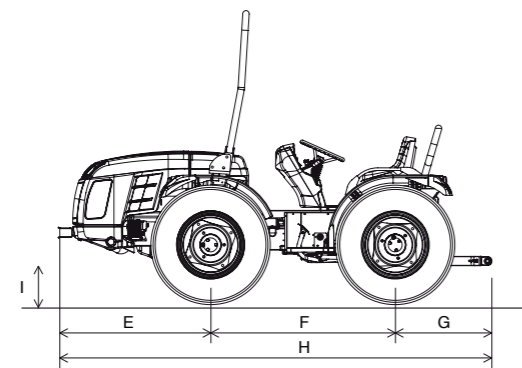
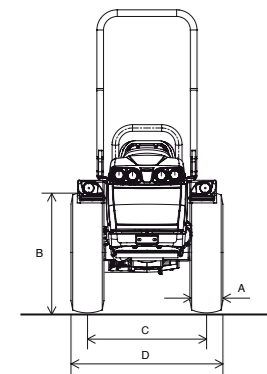

	COBRAM 60 AR
CHASSIS	Swinging integral chassis OS-FRAME with central articulation
ENGINE	4-cycle Diesel engine with direct injection
Manufacturer	KOHLER
Model	KDi 2504M
Number of cylinders	4
Displacement cm ³	2482
Suction	Naturally aspirated
Power KW/HP	36 / 49
Nominal speed [rpm]	2600
Maximum tractor torque (Nm/rpm)	170 / 1500
Cooling	Water
Tank capacity (lt.)	45
TRANSMISSION	Synchronized gearbox: 24 speeds (12 forward and 12 reverse) with synchronized reverser
Main clutch	Multidisc, in oil bath
DIFFERENTIAL	Front and rear with simultaneous differential lock and electro-hydraulic control
AXLES	Front and rear, with epicyclic reduction units
DRIVE	Four-wheel drive, permanent
POWER TAKE-OFF	Rear, independent from the gearbox, 540 r.p.m. and synchronized with the gearbox. Engageable under load with brake in disengaged position
PTO clutch	Multidisc, in oil bath
Engagement control	Electro-hydraulic
HYDRAULIC SYSTEM	Double circuit with independent pumps
Flow rate to the hoist and the distributors (l/min.)	25,6
Flow rate to hydraulic pump which controls the hydroguide and electro-hydraulic control (l/min.)	15,3
Maximum hydraulic pressure [bar]	180
DISTRIBUTORS	Mechanical control to max. 6 hydraulic couplers
Rear (standard)	1 double acting (Hydraulic lift by rams) 2 double acting (Draft and position control)
Rear (optional)	1 single acting and 1 double acting with float or 2 double acting in addition to the standard one (Hydraulic lift by rams) 1 single acting and 1 double acting with float instead of the standard one (Draft and position control)
ELECTRIC SYSTEM	
Battery (Ah)	100
Alternator (A)	80
REAR LIFT	Standard: by two external rams - Optional: draft and position control
Three-point hitches	Standard: standard couplers cat. 1 - Optional: quick couplings cat. 1, L-shaped lift arms, lift rods adjustable in length and hooks adjustable in width
Three-point tie bar	With manual adjustment
Lifting capacity at the end of the arms kg	1200
DRIVING UNIT	
Driving platform	Monodirectional or reversible with rotating platform and twin pedal assembly
Steering wheel	Adjustable
SEATS	Standard: sprung seat - Optional: 'Bostrom' seat (only for monodirectional version)
SERVICE BRAKES	Oil immersed multidisc, acting on the rear transmission, with mechanical control
STEERING	Acting on the service brakes
SAFETY	With hydrostatic steering by two rams, acting on the central articulation. Flow deviator for steering unit for the reversible version
Roll-bar frame (standard)	Front, homologated
CONSOLE	
Digital type	With chrono-tacho-gyrometer, water thermometer, control warning lights and acoustic alarm. Reading of rpm, forward speed and rotation speed of power takeoff
TYRES	
Standard	8.25-16
Optional	250/80-18 * 280/70R18 * 320/65R18 * 260/70-20 * 31x15.50-15 XTC and STG * 31x13.50-15 Garden
TOW HOOKS	
Standard	Rear CUNA and front
Optional	Rear rotating, EC approved
WEIGHT OPERATIONAL	
With roll-bar (kg)	1550
OPTIONAL	Flash light, front weight and weights for wheels